

Model EGPE-2A Accelerometer



+260°C PE Accelerometer
Wide Bandwidth
Hermetically Sealed
Through Hole Mount



The Model EGPE-2A is a piezoelectric charge mode accelerometer designed for high frequency vibration and shock measurements. The accelerometer incorporates an annular shear mode crystal that provides stable thermal response up to +260°C. The model EGPE-2A is hermetically sealed and features the popular through hole mount installation for use with standard mounting screws.

FEATURES

- ±50g to ±2000g Dynamic Range
- Wide bandwidth up to 15kHz
- Through Hole Mount
- Hermetically Sealed
- Annular Shear Mode
- Isolated Mounting Surface
- Stable Temperature Response

APPLICATIONS

- Vibration & Shock Monitoring
- High Temperature Applications
- Flight Testing
- Gearbox Vibration Monitoring
- High Frequency Applications

dimensions

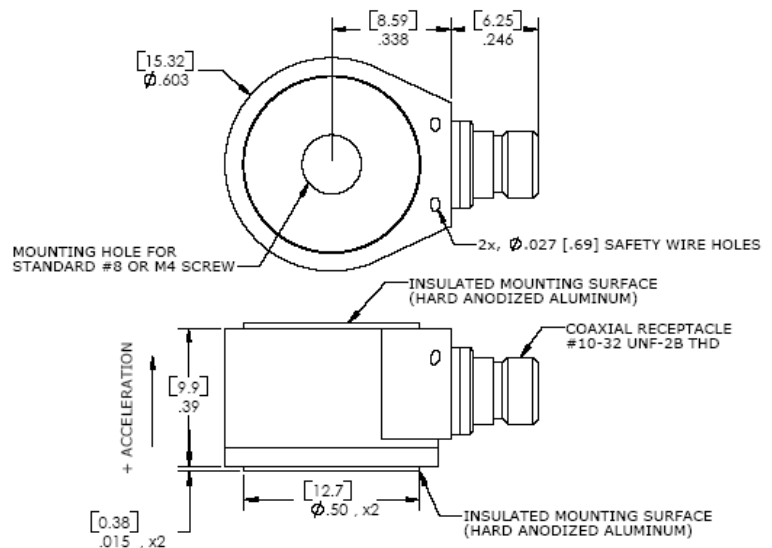

Model EGPE-2A Accelerometer

performance specifications

All values are typical at +24°C, 100Hz unless otherwise stated. Measurement Specialties reserves the right to update and change these specifications without notice.

Parameters				Notes
DYNAMIC				
Range (g) ¹	±50	±500	±2000	
Sensitivity (pC/g)	20	13	6.5	
Frequency Response (Hz) ²	1-5000	1-10000	1-12000	±5%
Frequency Response (Hz) ²	0.1-10000	0.1-15000	0.1-15000	±1dB
Natural Frequency (Hz)	40000	45000	48000	
Non-Linearity (%FSO)	±1	±1	±1	
Transverse Sensitivity (%)	<5	<5	<5	
Shock Limit (g)	5000	5000	5000	
ELECTRICAL				
Capacitance (pF)	1050	1050	1050	Nominal
Insulation Resistance (MΩ)	>100	>100	>100	@50Vdc
Grounding	Case Grounded			
Ground Isolation	Isolated from Mounting Surface			
ENVIRONMENTAL				
Temperature Response (%)	±10	±10		
Operating Temperature (°C)	-55 to +260			
Storage Temperature (°C)	-55 to +260			
PHYSICAL				
Sensing Element	Ceramic (shear mode)			
Case Material	Stainless Steel			
Cable	Not Applicable			
Weight (grams)	11			
Mounting	Through Hole (#8 or M4 cap screw)			
Mounting Torque	16 lb-in (1.8 N-m)			
AWG	Not Applicable			

¹ Operating range over which the accelerometer meets the linearity specifications

² Low-end response of the accelerometer is a function of its associated electronics.

Supplied accessories:	AC-D02787	1x #8-32 Mounting Screw (5/8 inch length)
Optional accessories:	310-XXX	Cable Assembly, 10-32 to 10-32 (XXX designates length in inches, 10ft standard)
	AC-D02327	Triaxial Mounting Block
	AC-D02328	Adhesive Mounting Adaptor
	AC-D02636	Magnetic Mounting Adaptor

The information in this sheet has been carefully reviewed and is believed to be accurate; however, no responsibility is assumed for inaccuracies. Furthermore, this information does not convey to the purchaser of such devices any license under the patent rights to the manufacturer. Measurement Specialties, Inc. reserves the right to make changes without further notice to any product herein. Measurement Specialties, Inc. makes no warranty, representation or guarantee regarding the suitability of its product for any particular purpose, nor does Measurement Specialties, Inc. assume any liability arising out of the application or use of any product or circuit and specifically disclaims any and all liability, including without limitation consequential or incidental damages. Typical parameters can and do vary in different applications. All operating parameters must be validated for each customer application by customer's technical experts. Measurement Specialties, Inc. does not convey any license under its patent rights nor the rights of others.

ordering info

PART NUMBERING Model Number+Range

EGPE-2A-GGGG

|
| _____ Range (0500 is 500g)

Example: EGPE-2A-0500
Model EGPE-2A, 500g